

NCERT Class 10 Science Notes

Chapter 12 - Electricity

Introduction

- The Greek words "**Electrica**" and "**Elektron**" were used to describe **electricity**.
- **Thales, a Greek philosopher**, was the first to notice how certain elements attract other materials when rubbed together.
- These materials were divided into two categories by **Gilbert: vitreous** and **resinous**, as **Positive charges** and **Negative charges**.

Frictional Electricity

- Fur, flannel, wax, glass, cotton, paper, silk, human skin, wood, metals, rubber, resin, amber, sulphur, and ebonite are just a few of the materials used.
- If any two materials in this series are rubbed together, the element that occurs initially in the series will get positive charge, while the element that occurs later in the series will gain negative charge.

Fundamental Laws of Electrostatics

- **Positive** and **negative charges** are the two types of charges.
- Charges that are **similar repel** each other, while charges that are **dissimilar attract** each other.

Coulomb's Law

- $F \propto \frac{(q_1 q_2)}{r^2}$
- The **electrostatic attraction** or **repulsion force** between two charges is **proportional** to the **product of their charges** and **inversely proportional to the square of their distance**.
- $F = \frac{(Kq_1 q_2)}{r^2}$
- K is the **constant of proportionality** and is equal to $9 \times 10^9 \text{Nm}^2/\text{C}^2$ for free space.
- The force is **repulsive** for **similar charges** and **attracting** for **dissimilar** ones.

Charge Conservation

- When an **ebonite rod** is brushed with **fur**, the ebonite gains a **negative charge**, while the **fur** gains a **positive charge**.
- This indicates that electrons have transferred from fur to ebonite.
- The system's net charge stays unchanged.
- As a result, **charges are not generated or destroyed; rather, they are moved from one material to another.**

Insulators and Conductors

- **Insulators** are **poor conductors of electricity**, yet they can be quickly charged through friction.
- **Charges** can flow freely through conductors.

Current

- The **rate of charge flow** is referred to as current.
- If the charge q is in coulomb and t is the time in seconds then, current is

$$I = \frac{q}{t}$$

- The SI unit of current is **ampere (A)**.
- **Current** is a **scalar quantity**.
- **Example:**

A current of 1A is drawn by a filament of an electric bulb for 20 minutes. Find the amount of electric charge that flows through the circuit.

Ans:

The given data is,

$$I = 1\text{A and}$$

$$t = 20 \text{ minutes}$$

$$t = 20 \times 60$$

$$t = 1200 \text{ seconds}$$

Therefore,

$$I = \frac{q}{t}$$





Electric charge is





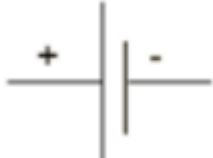

$$q = It$$

$$q = 1 \times 1200$$

$$q = 1200 \text{ C}$$

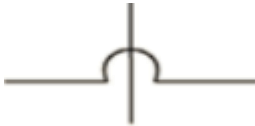
Symbols used in electric circuit

Electric Component	Function/ Description	Symbol
Connecting Wire	A straight line represents a connecting wire . It's commonly constructed of copper and has insulation on both ends to link two places electrically .	
Resistor	A zip zap line is used to depict the resistor . Brass terminals are represented by two heavy dots at the ends , to which a wire is attached. Alloys like as nichrome, manganin, constantan, and eureka are commonly used to make resistor wire .	
Cell	The positive terminal of a cell is represented by a thin long line , while the negative terminal is represented by a thick and short line . Electrical current source .	
Fuse	In an electric circuit, to limit the current .	
Plug key	To build or break an electric circuit for an extended period of time.	Open key ——— () Closed key ——— (•)
Battery	A cell that is made up of two or more cells. The cells are placed in a row here. Electrical current source .	

Electric bulb	When voltage is placed across the terminals of an electric device, such as an incandescent lamp, glow lamp, or fluorescent lamp, it creates light.	
Connecting wires	Wires are linked together.	
Connecting wires	Crossing wires that aren't linked.	
Voltmeter	It's a device that measures the difference in potential between two locations in an electric circuit.	
Ammeter	It's a tool for determining current in an electric circuit.	
Alternating current	Alternating current is a type of current that changes direction fast on its own.	

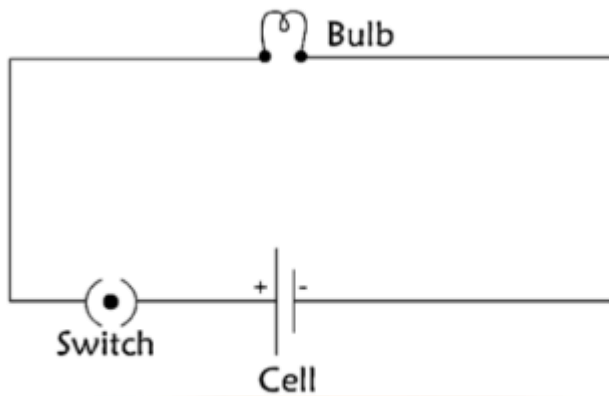

A circuit diagram is a diagram that displays how different components in a circuit have been connected using traditional component symbols.

Electrical Potential

- **Electric potential** is the work done in carrying a unit positive charge from infinity to a point.
- If W is the work done q is the charge, then electric potential

$$V = \frac{W}{q}$$

- The SI unit of **electric potential** is **Volts (V)**

Electric Potential Difference

- The work done required to move a unit charge from one location to the other is defined as the **electric potential difference** between two points in an electric circuit carrying some current.

$$\text{Potential difference (V) between two points} = \frac{\text{Work done (W)}}{\text{Charge (Q)}}$$

- The electric potential difference between points A and B is,

$$V_{AB} = \frac{\text{Work done to carry charge } q \text{ from A to B}}{\text{Charge (Q)}}$$

- The SI unit of **electric potential difference** is Volts (V).

● Example:

How much work is done in moving a charge of 4 C across two points having a potential difference 24 V?

Ans:

Given data is,

Charge, $Q = 4 \text{ C}$

Potential difference, $V = 24 \text{ V}$

Therefore, the amount of work W done in moving the charge can be calculated as,

$$W = V \times Q$$

$$W = 24 \times 4$$

$$W = 96 \text{ J}$$

Electric Potential energy

- The work done required to transport charges to their proper places against the electric field using a source of energy is known as **electric potential energy**.
- The potential energy of the charges is used to store the work done.

Ohm's Law

- **Under similar physical conditions, the current flowing through a wire is directly proportional to the difference in potential applied across its ends.**

$$V \propto I$$

$$\frac{V}{I} = \text{Constant}$$

$$\frac{V}{I} = R$$

Therefore,

$$V = IR$$

Where R is the resistance offered.

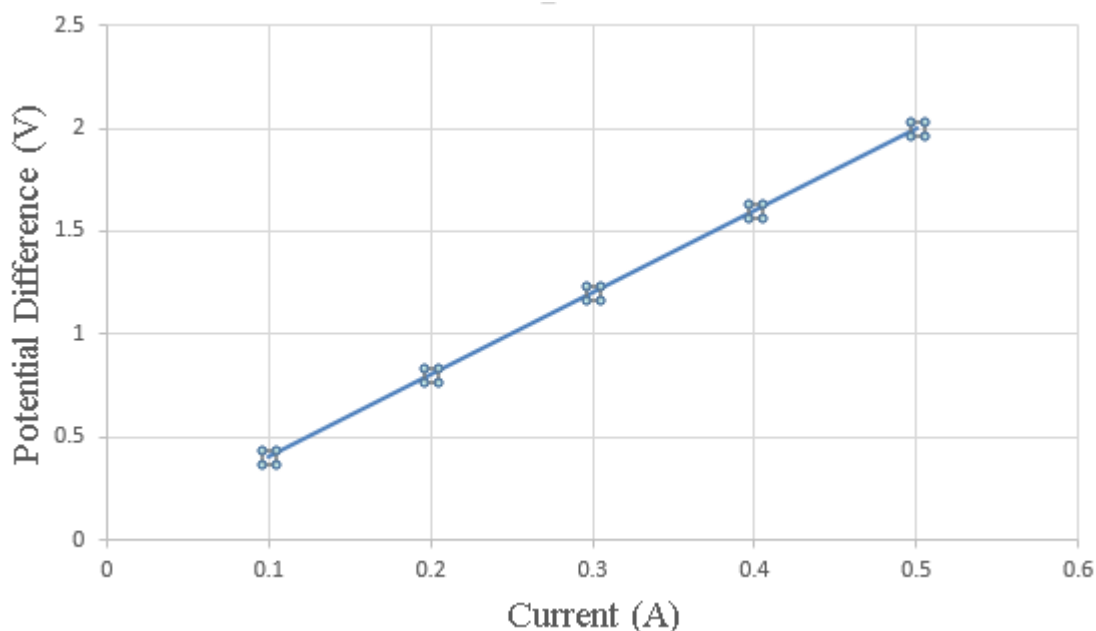

Resistance

- Resistance is the opposition to the flow of current.
- The SI unit of resistance is Ohm (Ω).
- 1 Ohm is the resistance offered by a wire carrying 1 A current when 1 V is applied across its ends.
- $R = \frac{V}{I}$
- $1 \text{ Ohm} = \frac{1 \text{ Volt}}{1 \text{ Ampere}}$
- **Variable resistance** is a component that **regulates current without changing the voltage source**.
- A **rheostat** is a device that is commonly used to **adjust the resistance** in an electric circuit.

Factors Affecting Resistance

- A conducting wire's resistance is determined by:
 1. Nature of the material of the wire [Resistivity (Ω)]
 2. Length of the wire (l)
 3. Cross-sectional area of the wire (A)
- Resistance is directly proportional to its length (l) and inversely proportional to the area of cross-section (A).

That is,

$$R \propto l$$

$$R \propto \frac{1}{A}$$

Therefore,

$$R \propto \frac{l}{A}$$

$$R = \rho \frac{l}{A}$$

Where,

ρ (rho) is a **proportionality constant that refers to the electrical resistivity of the conductor's substance**.

Resistivity

- The resistance offered by a wire of unit length and unit cross-sectional area is called resistivity.
- Resistivity is also known as **specific resistance**.
- Ωm ohm-meter is the SI **unit for resistivity**.

- Metals and alloys have **very low resistivity** which in the range of $10^{-8}\Omega\text{m}$ to $10^{-6}\Omega\text{m}$.
 - The resistivity of insulators such as rubber and glass are on the order of $10^{12}\Omega\text{m}$ to $10^{17}\Omega\text{m}$.
 - Temperature affects both a material's resistance and its resistivity.
 - An **alloy's resistivity** is usually **higher** than that of its constituent metals.
 - At high temperatures, alloys **do not easily oxidize** (burn) and hence, they're frequently used in **electrical heating devices** like electric irons and toasters.
 - **Tungsten** is nearly exclusively utilized in electric bulb filaments, while copper and aluminium are commonly used in electrical transmission lines.
 - Reciprocal of resistivity is called **conductivity**.
 - Conductivity can be calculated as;
- $$\sigma = \frac{1}{\rho}$$
- SI unit of conductivity is $\text{ohm}^{-1}\text{m}^{-1}$ or $\text{mho}\cdot\text{m}^{-1}$

Effect of Temperature

- A conductor's resistance increases linearly as the temperature rises.
- As the temperature rises, an insulator's resistance rises as well.
- As a semiconductor's temperature rises, its resistivity falls.
- The resistivity of an alloy increases as the temperature rises.

Semiconductors and Superconductors

- Semiconductors are materials with resistivity that fall between those of an insulator and a conductor.
- Materials which lose their resistivity at low temperatures are called superconductors.

Examples:

- i. **The potential difference between the terminals of an electric heater is 45 V when it draws a current of 3 A from the source. What current will the heater draw if the potential difference is increased to 120 V?**

Ans:

Given data is,

Potential difference $V = 45 \text{ V}$ and current $I = 3 \text{ A}$

According to Ohm's law,

$$R = \frac{V}{I}$$

$$R = \frac{45}{3}$$

$$R = 15 \Omega$$

When the potential difference is increased to 120 V the current is given by

$$I = \frac{V}{R}$$

$$I = \frac{120}{15}$$

$$I = 8 \text{ A}$$

As a result, the heater's current becomes 8 A.

- ii. A wire of given material having length l and area of cross-section A has a resistance of 8Ω . What would be the resistance of another wire of the same material having length $\frac{l}{4}$ and area of cross-section $2A$?**

Ans:

For first wire, resistance is;

$$R_1 = \rho \frac{l}{A} = 8 \Omega$$

Now, for the second wire, resistance is

$$R_2 = \rho \frac{\frac{l}{4}}{2A}$$

$$R_2 = \rho \frac{l}{8A}$$

$$\text{Since, } l = \frac{l}{4}$$

Therefore,

$$R_2 = \rho \frac{l}{8A}$$

$$R_2 = \frac{1}{8} R_1$$

$$\text{Since, } R_1 = 8 \Omega$$

Therefore, R_2 becomes

$$R_2 = \frac{1}{8} \times 8$$

$$R_2 = 1 \Omega$$

As a result, the new wire's resistance is 1Ω

Resistances in Series

- The sum of the individual resistances of multiple resistors in series equals their equivalent resistance.
- If resistances R_1 , R_2 and R_3 are connected in **series**, then **the equivalent resistance** can be calculated as,

$$R_s = R_1 + R_2 + R_3$$

- When numerous resistors are connected in series, the combined resistance R_s equals the total of their individual resistances R_1 , R_2 , R_3 and hence, R_s is greater than any individual resistance.
- In series circuit, **current remains the same and potential difference vary.**

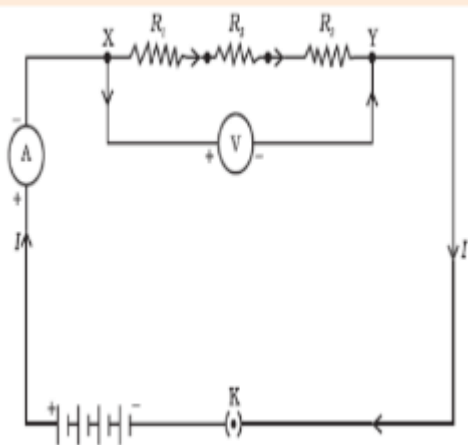

- The current in a series circuit is constant throughout the electric circuit. As a result, connecting an electric lamp and an electric heater in series is clearly impractical, as they require currents of vastly different values to function effectively.
- The main disadvantage of a series circuit is that if one component fails, the circuit is broken and none of the other components works.

- **Example:**

An electric lamp, whose resistance is 25Ω , and a conductor of 5Ω resistance are connected to a 9 V battery as shown in below figure. Calculate

- a. The total resistance of the circuit,
- b. The current through the circuit.

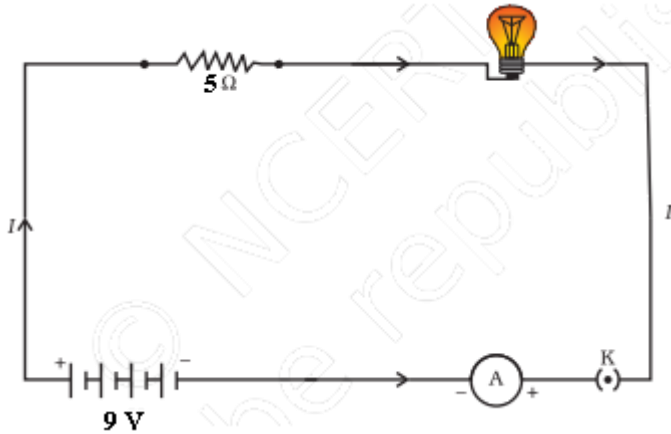

Ans:

The resistance of electric lamp,

$$R_1 = 25 \Omega$$

The resistance is connected in series,

$$R_2 = 5 \Omega$$

Then the total resistance in the circuit can be calculated as,

$$R_s = R_1 + R_2$$

$$R_s = 25 + 5$$

$$R_s = 30 \Omega$$

The overall difference in potential across the battery is

$$V = 9 \text{ V}$$

According to Ohm's law, the current through the circuit can be calculated as;

$$I = \frac{V}{R_s}$$

$$I = \frac{9}{30}$$

$$I = 0.3 \text{ A}$$

Resistances in Parallel

- If resistances R_1 , R_2 and R_3 are connected in parallel, then the equivalent resistance R_p is given by

$$\frac{1}{R_p} = \frac{1}{R_1} + \frac{1}{R_2} + \frac{1}{R_3}$$

- The sum of the reciprocals of the individual resistances is equal to the reciprocal of the equivalent resistance of a group of resistances linked in parallel.

- In parallel circuit, **potential difference remains the same and current will be vary.**
- The current flowing through the electrical devices is divided in a parallel circuit.
- This is especially useful when each device has a different resistance and requires a varied amount of current to function properly.

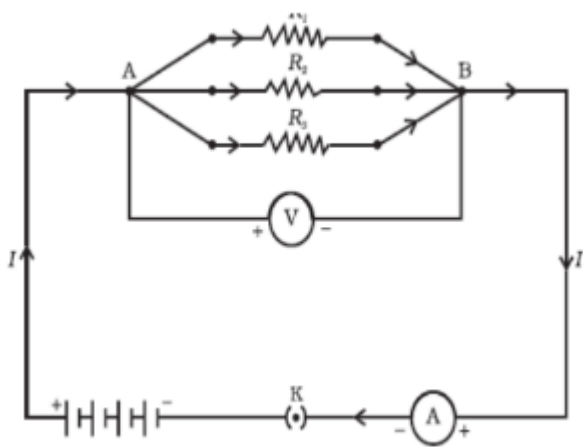

• **Example:**

In the circuit diagram given in below figure, suppose the resistors R_1 , R_2 and R_3 have the values 2Ω , 4Ω , 6Ω respectively, which have been connected to a battery of 9 V .

Calculate

- The current through each resistor,
- The total current in the circuit, and
- The total circuit resistance.

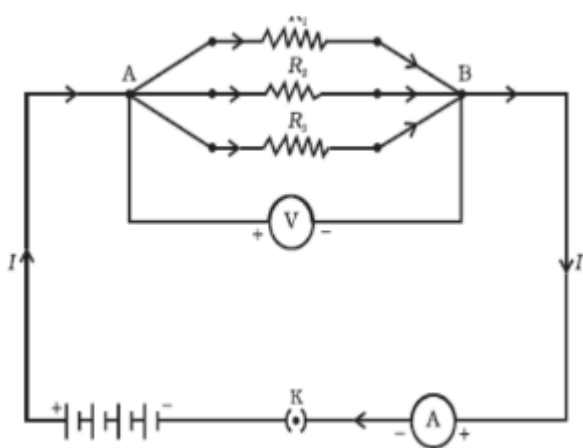

Ans:

Given that

$$R_1 = 2 \Omega$$

$$R_2 = 4 \Omega$$

$$R_3 = 6 \Omega$$

The total potential difference across the battery is

$$V = 9 \text{ V}$$

According to Ohm's law,

$$\text{The current } I_1, \text{ through } R_1 = \frac{V}{R_1}$$

$$I_1 = \frac{V}{R_1}$$

$$I_1 = \frac{9}{2} \text{ A}$$

$$I_1 = 4.5 \text{ A}$$

$$\text{The current } I_2, \text{ through } R_2 = \frac{V}{R_2}$$

$$I_2 = \frac{V}{R_2}$$

$$I_2 = \frac{9}{4} \text{ A}$$

$$I_2 = 2.25 \text{ A}$$

$$\text{The current } I_3, \text{ through } R_3 = \frac{V}{R_3}$$

$$I_3 = \frac{V}{R_3}$$

$$I_3 = \frac{9}{6} \text{ A}$$

$$I_3 = 1.5 \text{ A}$$

Therefore, the total current in the circuit can be calculated as;

$$I = I_1 + I_2 + I_3$$

$$I = 4.5 + 2.25 + 1.5$$

$$I = 8.25 \text{ A}$$

The total resistance R_p can be calculated as;

$$\frac{1}{R_p} = \frac{1}{R_1} + \frac{1}{R_2} + \frac{1}{R_3}$$

$$\frac{1}{R_p} = \frac{1}{2} + \frac{1}{4} + \frac{1}{6}$$

$$\frac{1}{R_p} = \frac{11}{12}$$

Therefore,

$$R_p = \frac{12}{11} \Omega$$

Heating Effect of Electric Current

- The source energy is constantly dissipated fully in the form of heat if the electric circuit is purely resistive, that is, a configuration of resistors exclusively connected to a battery, this effect is called as **the heating effect of electric current**.

- Electric heaters, electric irons, and other gadgets are operating on this effect.
- For a steady current I , the amount of heat H produced in time t can be calculated as;

$$H = VIt$$

- **Joule's Law of Heating:**

When a current I flows through a resistor R heat is produced and this phenomena is called as **Joule's law of heating**.

$$H = I^2Rt$$

- **Example:**

120 J of heat is produced each second in a 6Ω resistance. Find the potential difference across the resistor.

Ans:

Given data is

$$H = 120 \text{ J}$$

$$R = 6 \Omega$$

$$t = 1 \text{ sec}$$

According to Joule's Law of Heating effect,

$$H = I^2Rt$$

Therefore,

$$I = \sqrt{\frac{H}{Rt}}$$

$$I = \sqrt{\frac{120}{6 \times 1}}$$

$$I = \sqrt{20}$$

$$I = 4.47 \text{ A}$$

Thus the potential difference across the resistor V can be calculated as;

$$V = IR$$

$$V = 4.47 \times 6$$

$$V = 26.82 \text{ V}$$

Applications of Heating Effect of Electric Current

- Heat creation in a conductor is an unavoidable result of electric current.
- Heat is undesirable because it converts useful electrical energy into heat.
- The electric laundry iron, electric toaster, electric oven, electric kettle, and electric heater are all examples which are working on Joule's heating effect.
- As in an electric bulb, electric heating is also employed to produce light.
- Bulb filaments are made of tungsten, a strong metal with a high melting point.
- The **fuse** used in electric circuits is another prominent application of Joule's heating.

Fuse Wire:

- A **fuse wire** is a wire that melts, breaks the circuit, and protects various appliances in household connections from damage.
- It protects circuits and appliances by interrupting any too high electric current flow.
- The fuse is connected to the device in series.
- It consists of a piece of wire made of a metal or an alloy with the proper melting point, as well as a piece of wire made of a metal or an alloy with the appropriate melting point.
- **Aluminium, copper, iron, and lead alloys** are used to make fuse wires.
- **The maximum safe current that can pass through the fuse wire increases as the thickness of the wire increases.**

Electrical Energy

- Because of the existence of resistance to the flow of current work has to be done in order to maintain the flow of current.
- Since the potential difference V is the work done to carry unit positive charge from infinity to a point, the work done to carry a charge q is given by:

$$W = qV$$

$$\text{But } I = \frac{q}{t}$$

Therefore,

$$W = ItV$$

Since $V=IR$

Therefore,

$$W = I^2Rt$$

$$W = \frac{V^2t}{R}$$

- This **work done** is stored as energy.
- SI **unit of electrical energy** is **Joule**.

Electric Power

- The rate at which electric energy is consumed is called electric power.

- Power = $\frac{\text{Work done}}{\text{Time}}$

$$P = \frac{W}{t}$$

$$P = V \times I^2R$$

$$P = V^2R$$

$$P = VI$$

- SI unit of electric power is **Watt**.
- Example:

An electric bulb is connected to a 230 V generator. The current is 0.75 A. What is the power of the bulb?

Ans:

We have

$$V = 230 \text{ V}$$

$$I = 0.75 \text{ A}$$

Thus, Power can be calculated as;

$$P = VI$$

$$P = 230 \times 0.75$$

Therefore,

$$P = 172.5 \text{ W}$$

Calculation of Power for House Hold Electricity

- The commercial unit for **electrical energy** is the **kilowatt hour (kWh)**
 $1\text{kWh} = 3,600,000 \text{ J}$
 $1\text{kWh} = 3.6 \times 10^6 \text{ J}$
- No. of units of electricity consumed in a household can be calculated as;
 No. of units of electricity consumed in a household = No. of kWh
- Total cost of electricity = Total units \times Cost per unit of electricity